



---

## **Martin 242 Class Rules – Measurer’s Handbook**

In effect March 1, 2025

*Prepared by:*

*Anthony Collett, Ken Machtley, Ken Holland, Chris White, James Hyslop, Frank Rogers, Tim Murphy, Craig Strand, and Michael Clements*

Measurers: Please note that some Class Rules have been left in this Handbook “*in black or red italic print*” to draw your attention to their importance and/or measurement issues and solutions regarding those Rules.

Secondly, please note that the following boat elements are the ones that make the most difference to boat performance and thus should be given the greatest consideration and review by a Measurer:

1. Keel shape
2. Rudder shape
3. Forestay span
4. Boat weight
5. Corrector weight placement

Third, in terms of boat integrity issues, the following items are considered to be essential items to have installed on any M242:

1. Backing plate on the forestay stem that the forestay attaches to, or the “toe-cap” of the deck may peel off the bow
2. G10 or similar 18” to 24” long rods to provide backing for the shroud u-bolts, bedded in using epoxy via the standard MG Marine installation process (see the Fleet 1 website in this regard)

Fourth, any tape measures should be metal and not cloth so as to avoid the potential for stretching.

Fifth, with regard to the Hull Identification Number (“HIN”), these were usually drilled into the upper right corner of the transom, but occasionally could be found in the keel attachment area, but sometimes no number is to be found at all - it may never have been applied or the drill holes were filled in and painted over at some point. The methodology for interpreting the numbers is as follows (as an example, we’ll use serial number ZYJ100190282)

- ZYJ (builder code) = Martin Yachts Ltd
- Next two digits (10) = Model number (10 = M242)
- Next three digits (019) = hull number, so in this case #19
- Next two digits (02) = month of production, so in this case February
- Final two digits (82) year of production, so in this case 1982



## 1. Intent

*The M242 was created as a strict one design class. The intent is that all boats will be equal and that competition will be a true test of the crews, not boats and equipment. Any effort to alter the boat or its rigging, except as specifically permitted by these rules, is prohibited. Contact the Fleet Measurer before making any modifications.*

### 1.1 Measurement Certificate

*All boats shall have a valid **Measurement Certificate**.*

### 1.2 Governance

*In accordance with the IMCA Constitution (Part 7 – Changes, subsections 33 & 34) and the Class Rules, a Fleet must propose all suggested Rule changes to the IMCA Technical Committee so that the Committee can decide if the change should be Class-wide or just remain a Local Fleet Variance.*

*Furthermore, Local Fleet Variances shall be listed in this IMCA Class Rules document in the appropriate sections, and identified as a specific Local Fleet Variance, so that Members in any Fleet can refer to these Class Rules and readily understand what Local Fleet Variances, if any, are in effect for each Fleet.*

### 1.3 Measurement

*All boats, sails, and equipment shall be measured in accordance with the current World Sailing Equipment Rules of Sailing, which provides measurement process guidelines, as well as definitions for **bolded** terms found in this document, such as Upper Point, Lower Point, Outer Point, Limit Marks, etc., except as amended in the defined terms found below in Section 2.*

## 2. Definitions

### 2.1 Builder

*"**Builder**" means any manufacturer authorized by Martin Yachts Ltd. to produce the Martin 242 and accepted by the International Martin 242 Class Association ("IMCA").*

### 2.2 Mast Datum

*The centerline of the hole that the headstay attaches to is the "**Mast Datum**". The mast point that the headstay attaches to is also known as the mast lug or a mast ear. [Measurers: please see comments in Rule 3.2 re "drifting Datum holes"](#).*

### 2.3 Plinth

*The raised smooth flat surface immediately surrounding the mast boot collar is the "**Plinth**".*

### 2.4 Measurement Certificate

*"**Measurement Certificate**" is that certificate which states whether or not a boat, its sails, rigging, fittings, and weight conform to the Class Rules. Variances to the Class Rules, special dispensations from Fleet Measurers, or IMCA waivers, shall be noted on the Measurement Certificate.*

*Measurement Certificates are issued, and remain valid, in accordance with the IMCA Constitution, Part 6.*

*2.4.1 Fleet 3 Local Variance: Each boat shall be measured and weighed every 3 years.*

### **3. Measurement and Specifications**

#### **3.1 Keel and Rudder**

*Except as provided in 3.1.1, all keels and rudders shall conform to the measurements in Appendix B of these rules.*

*3.1.1 Boats with keels and rudders that do not meet these measurements shall apply for dispensation from IMCA through the Fleet Measurer. Dispensation shall be contingent upon the establishment that no modifications have ever been undertaken to alter the keel or rudder in such a way as to move its measurements or characteristics away from the Appendix B specifications.*

*3.1.2 The sections and profiles of the keel and rudder may only be altered to comply with Appendix B, and this includes repairing or fairing of the keel or rudder.*

*3.1.3 Competitors should discuss pending changes with a Fleet Measurer prior to any modifications of a keel or rudder.*

*Measurers: See additional notes re the Keel & Rudder measurement process in Appendix B. Secondly, any boat that has been granted a temporary Dispensation for a measurement discrepancy has to address that issue within the time granted or the boat is not eligible to race in Championship events. If a boat changes hands before a measurement discrepancy is addressed, then the new owner may be granted a suitable time period (at the Measurer's discretion) to address the issue.*

*However, this does not mean that if the first owner was given a year to fix an issue that the new owner would also get another year. This would merely perpetuate the problem from owner to owner.*

*It is probably more appropriate to grant only 1/3<sup>rd</sup> of a year or 1/2 a year, depending on the new buyer's circumstances and time of year when the transaction occurs (so for example, if the transaction occurs in October the new buyer gets 6 months to address the Deficiency, but if it occurs in January they only get 3-4 months...)*

#### **3.2 Spars and Rigging**

*Measurer's Handbook Note: The best approach to measuring a mast is to do it when it is out of the boat and lying flat on the ground or elevated on sawhorses or similar. It is possible to measure most of the critical aspects of a mast while it is elevated in the boat, but it is not ideal nor quite as accurate. This section will talk about both methods. In general, spar measurements are to the inside of the limit marks (i.e., to the inside of the band).*

*However, there is one preliminary measurement that is best done when the mast is in the boat, and that is 3.2.3 with regard to the Plinth measurement. And it does not matter if the boat is on a trailer or in the water when the Plinth measurement is taken.*



In an ideal world, before the mast is taken out of the boat for measuring, 3.2.3 is done first (assuming either the Lower Band is in place or a piece of black tape (or a felt pen mark) takes its place temporarily whereby the upper edge of the tape is roughly in line with the top of the boom or the gooseneck fitting if the boom has already been detached). In this manner a “ballpark” Plinth measurement can be done and then adjusted later depending on all the other measurements higher up on the mast.

Note that gooseneck fittings have been moved on occasion due to the original holes having worn out and new ones being drilled higher or lower. Therefore any gooseneck that has been moved does not in turn create a new “Lower Point”, per se. The Lower Point position is driven solely by the Upper Point and in turn the Mast Datum.

A note regarding the Mast Datum: it is always the center point on the original hole drilled in the mast tang. If the hole has drifted downwards due to wear and tear, then the centerpoint needs to be extrapolated based on the original centerpoint position. And if a new hole has been drilled higher up on the tang, it does not become the new Mast Datum. If the original hole was filled with molten aluminum and redrilled, the Mast Datum is the original centerpoint on the tang if by any chance the newly drilled hole is not in exactly the same position.

### Mast and Fore-Triangle Geometry Measurements

Note; Measurements have a tolerance of +/- 1/4" (6mm) unless noted otherwise.

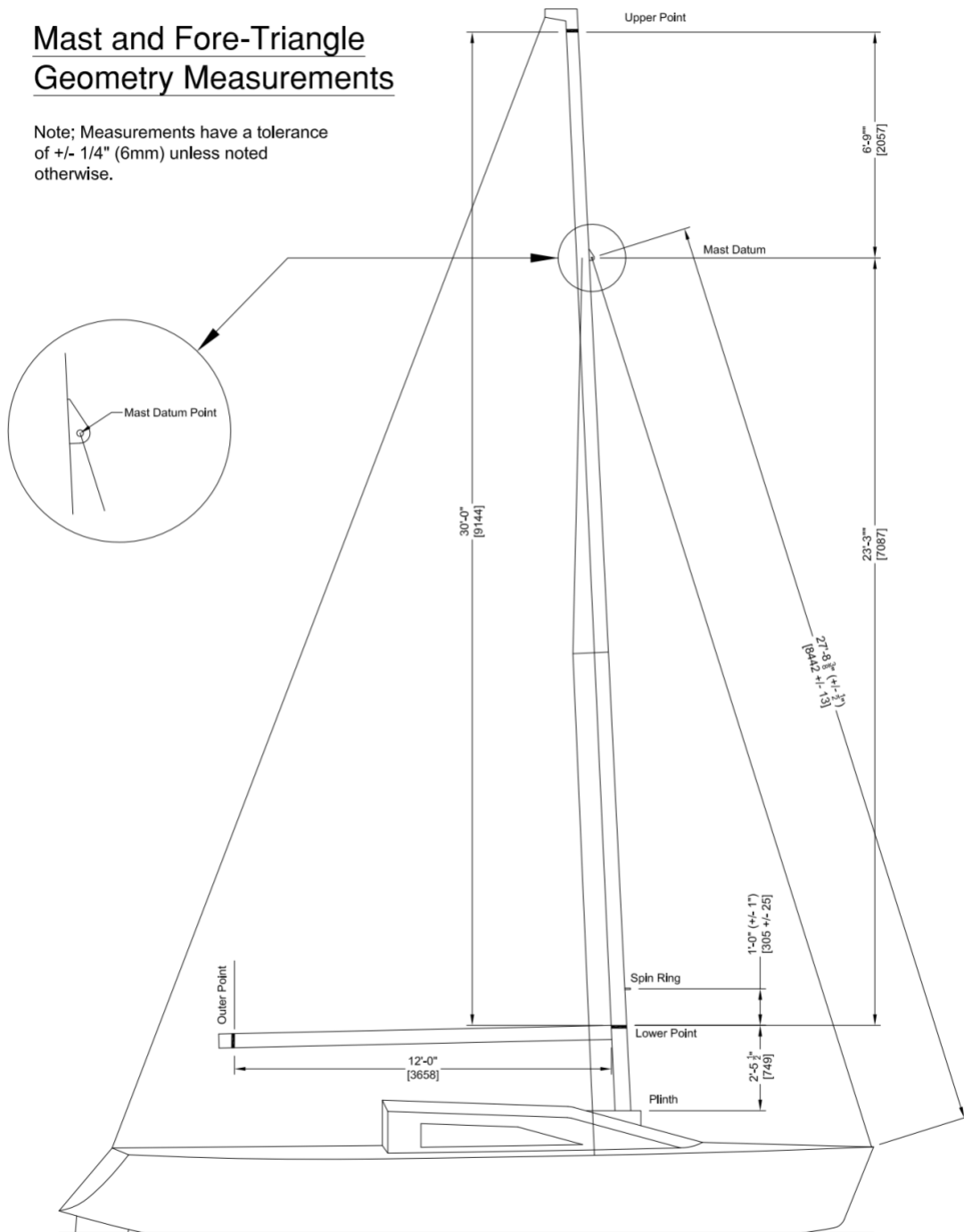

### Measurement Process When Mast Is Out Of Boat And Horizontal

1. Measure the Lower Point to Plinth first per 3.2.3, if possible, per the preamble. If the mast is already out of the boat, then deal with this issue later per point 5 below. A caveat if the mast is still in the boat temporarily or permanently: the shrouds need to be totally loose in order to get an accurate reading and to make an apples-to-apples comparison between various boats (consider this a best practice). Tight shrouds can cause the deck (and thus the Plinth) to rise by as much as 10mm-13mm on older, softer boats. Tensioning straps per 3.3.17 must also be loosened off.
2. Measure the mast length per 3.2.1
3. Measure from the Mast Datum to the lower edge of the Upper Point band per 3.2.2. Note that this Band can vary in position by 6mm either way. If no Band is in place, put a piece of colored electrical tape on the mast to take its place or a felt pen mark.
4. Measure from the lower edge of the Upper Point to the upper edge of the Lower Point per 3.2.2. Note that this Lower Band can vary in position by 6mm either way, but the two Bands together should not exceed 6mm total variance (as a best practice), or distortions in the overall One Design intent will occur. If no Band is in place, put a piece of colored electrical tape on the mast to take its place or a felt pen mark.
5. Per 3.2.3:
  - a. The first step is to measure from the flat Fiberglass support area around the mast step up to the lip of the mast collar (note that the collar lip is not necessarily level, so laying a ruler or a batten across the collar in a fore-aft orientation can provide an equalizing method). Then measure from the lip of the collar down to the Plinth.
  - b. Deduct this second number from the first number to arrive at a number for the base to Plinth amount.
  - c. Then measure from the bottom of the mast up to the upper edge of the Lower Point. Then deduct the “base to Plinth” amount and you arrive at the “Lower Point to Plinth” amount. It can be 749mm, plus or minus 6mm. At this point the question arises: if the Lower Band / Upper Band combo are moved 6mm in either direction, does this solve any Plinth measurement issue? Or does the boat need to get stainless or aluminum support plates placed under the mast step to raise it up, or (more drastically and rarely) does the mast need to be cut to shorten it so the Plinth issue is resolved? Before cutting a mast, check all calculations at least 3 times and possibly call in a 3rd party Measurer to review the situation. Usually a Plinth is out by no more than 10mm, but there are always exceptions, particularly if the support area under the mast step has been greatly compressed or the mast step was rebuilt in a manner that caused it to be raised by a significant amount.
6. Measure from the Mast Datum to the spreader bracket per 3.2.10. Note that this is not a critical measurement as it can vary depending on prior damage that required moving the spreader to a new location, or simply variance between mast builders, especially with the Gen 3 masts from Ballenger. Therefore, discrepancies can be noted, dispensed on the Measurement Certificate sub-section, and ignored.

7. Measure from the Mast Datum to the spinnaker hoist height per 3.2.12. Spinnaker hoist height is to the lower side of the spinnaker halyard lead (eye). This too is not a critical measurement and can be noted and Dispensated on the Measurement Certificate sub-section.
8. Measure the spreaders per 3.2.11. Note that these two measurements vary greatly depending on which mast manufacturer was used, and are not important measurements and thus discrepancies can be noted, Dispensated on the Measurement Certificate sub-section, and ignored.
9. Measure from the Lower Band to the spinnaker ring per 3.2.9 and check its diameter. This is also not a critical measurement.
10. Measure the Headstay span per 3.2.13 and remember that the allowable variance is 13mm or ½” either way, for a total of 26mm or 1”.
  - a. Note that this is a critical One Design equalizing measure and zero permanent dispensation can be granted for variances outside the allowed tolerance. Temporary Dispensation can be granted for perhaps 3-4 months to allow an owner to get: a new shackle for either end to adjust the overall length; a new forestay; a smaller or bigger furling drum (there are many types); remove a shackle (if any) below the furling drum; or to get the Mast Datum hole filled and redrilled. It is the Measurers’ discretion re the length of the Dispensation period, but it shouldn’t exceed 6 months.
  - b. Note: given that the furling drum gets in the way of doing this measurement, it is advisable to put a screwdriver thru the cross pin on the furling drum or any shackle attached to it and run the tape measure to an extension of that screwdriver (assuming it is at 90 degrees to the forestay).
  - c. Note 2: do not forget to add on the distance from the end of the furling drum or its shackle down to the toe cap (which is the deck/toe rail where the forestay tang exits the deck), especially if there is a lengthy “tang” sticking up that everything is attached to. The “span” is from the centerpoint of the Mast Datum to the toe cap. Final note: some boats have an adjustable turnbuckle incorporated in the forestay. The problem is that turnbuckles can be adjusted unless they are permanently “seized in place” via white or colored tape that is then marked and initialled by the Measurer so it cannot be readily undone and adjusted post-Measurement. “As supplied by the Builder” means no turnbuckles (thus they should be discouraged), but several boats have them so the above reasonable workaround solution precludes an owner having to pay for a new forestay.
11. Per 3.2.6, measure the Outer Point Distance on the boom. If no permanent Band is in place, use colored tape or felt pen to create one.
12. Lastly, measure the spinnaker pole. The length of the pole is very important and should not exceed 2515mm (8.25 feet) long overall including fittings, as an overly long pole provides obvious advantages on a dead-downwind leg. The diameter of the pole is not quite as important but needs to be no less than 51mm (.17 feet). It is the Measurer’s discretion if a pole is a few mm outside this diameter variance: close counts, as it is not a critical measurement.

### Measurement Process When Mast Is Vertical In The Boat

This alternate process is more challenging, and far less desirable (especially if the Upper Band is missing), in which case the only way to fully measure the mast is to take it down at some point and finish the measuring process. However, if the Upper Band is in place and the Measurer has access to a pair of strong binoculars, the critical elements can be dealt with while the mast is upright.

However, in order to be able to get the best binocular view of the end of the tape measure relative to various measurement points, it helps if the Measurer is elevated 10 feet or so on a nearby powerboat/sailboat upper deck, or the 242 being measured is dropped into the water (preferably at relatively low tide) and the Measurer stands on the upper dock to view the mast while another Measurer (or a boat rep) moves the tape measure up and down and calls out the numbers on the tape.

Here are the various steps, in sequence:

1. Raise a tape measure (attached to the main halyard) so that the very end of the tape measure is lined up with the Mast Datum. The end of the tape measure is ideally a highly visible stainless fitting/claw, or has white tape on it to delineate the end of the tape measure. In this manner, when using high-powered binoculars from 50'-75' away, it is possible to almost perfectly line up the tape measure end with the Mast Datum.
2. Take the reading from the Mast Datum to the upper edge of the Lower Point and make note of it. If no Lower Point exists, put some tape or a felt pen mark on the mast in line with the upper edge of the boom.
3. Raise the tape measure so the end of it lines up with the lower edge of the Upper Point. The total distance from the Lower Point to the Upper Point should be 30' per 3.2.2 when the two numbers are added together.
  - a. Note that the Lower Band can vary in position by 6mm either way, but the two Bands together should not exceed 6mm total variance (as a best practice), or distortions in the overall One Design intent will occur.
  - b. If no Upper Point exists, then after raising the tape measure by an additional 6.75' (2057mm), look through the binoculars to determine if it appears that the tape measure end is in approximately the right spot when compared with other M242 masts (if any are nearby). If the 1st measurement from the Lower Point to the Mast Datum plus 6.75' add up to 30' per 3.2.2, and then the end of the tape measure looks like it is roughly where an Upper Band should be, then you know the Lower Point is in approximately the right place.
4. Next, since the tape measure is elevated on the mast, measure from the Mast Datum to the spinnaker hoist height per 3.2.12. This is not a critical measurement and can be noted and Dispensated on the Measurement Certificate sub-section.
5. Then measure from the Mast Datum to the spreader bracket per 3.2.10, or postpone this item to when the mast is out of the boat. Note that this is not a critical measurement as it can vary depending on prior damage that required moving the spreader to a new location, or simply variance between mast builders, especially with the Gen 3 masts from Ballanger. Therefore, discrepancies can be noted, Dispensated on the Measurement Certificate sub-section, and ignored.
6. Measure the Headstay span per 3.2.13 by attaching the tape measure to the spinnaker halyard and remember that the allowable variance is 13mm or ½" either way, for a total of 26mm or 1".



- a. Note that this is a critical One Design equalizing measure and zero permanent dispensation can be granted for variances outside the allowed tolerance. Temporary Dispensation can be granted for perhaps 3-4 months to allow an owner to get: a new shackle for either end to adjust the overall length; a new forestay; a smaller or bigger furling drum (there are many types); remove a shackle (if any) below the furling drum; or to get the Mast Datum hole filled and redrilled. It is the Measurers' discretion re the length of the Dispensation period, but it shouldn't exceed 6 months.
  - b. Note: given that the furling drum gets in the way of doing this measurement, it is advisable to put a screwdriver thru the cross pin on the furling drum or any shackle attached to it and run the tape measure to an extension of that screwdriver (assuming it is at 90 degrees to the forestay).
  - c. Note 2: do not forget to add on the distance from the end of the furling drum or its shackle down to the toe cap, especially if there is a lengthy "tang" sticking up that everything is attached to. The "span" is from the centerpoint of the Mast Datum to the toe cap.
  - d. Final note: some boats have an adjustable turnbuckle incorporated in the forestay. The problem is that turnbuckles can be adjusted unless they are permanently "seized in place" via white or colored tape that is then marked and initialled by the Measurer so it cannot be readily undone and adjusted post-Measurement. "As supplied by the Builder" means no turnbuckles (thus they should be discouraged), but several boats have them so the above reasonable workaround solution precludes an owner having to pay for a new forestay.
7. Measure from the Lower Point to Plinth per 3.2.3. A caveat: the shrouds need to be totally loose in order to get an accurate reading and to make an apples-to-apples comparison between various boats. Tight shrouds can cause the deck (and thus the Plinth) to rise by as much as 10mm-13mm on older, softer boats. Tensioning straps per 3.3.17 must also be loosened off.
- a. The Plinth measurement can be 749mm, plus or minus 6mm. At this point the question arises: if the Lower Band / Upper Band combo are moved 6mm in either direction, does this solve any Plinth measurement issue? Or does the boat need to get stainless or aluminum support plates placed under the mast step to raise it up, or (more drastically and rarely) does the mast need to be cut to shorten it so the Plinth issue is resolved? Before cutting a mast, check all calculations at least 3 times and possibly call in a 3rd party Measurer to review the situation. Usually a Plinth is out by no more than 10mm, but there are always exceptions, particularly if the support area under the mast step has been greatly compressed or the mast step was rebuilt in a manner that caused it to be raised by a significant amount.
8. Measuring the mast length per 3.2.1 has to be done when the mast is out of the boat.
9. Measuring the spreaders per 3.2.11 has to be done when the mast is out of the boat.
- a. Note that these two measurements vary greatly depending on which mast manufacturer was used, and are not important measurements and thus discrepancies can be noted, dispensated on the Measurement Certificate sub-section, and ignored.
10. Measure from the Lower Band to the spinnaker ring per 3.2.9 and check its diameter. This is also not a critical measurement.

11. Per 3.2.6, measure the Outer Point Distance on the boom. Outer Point is measured from the aft side of the mast when the boom is mounted on the gooseneck. If no permanent black Band is in place, use colored tape or felt pen to create one.
12. Lastly, measure the spinnaker pole. The length of the pole is very important and should not exceed 2515mm (8.25 feet) long overall including fittings, as an overly long pole provides obvious advantages on a dead-downwind leg. The diameter of the pole is not quite as important but needs to be no less than 51mm (.17 feet). It is the Measurer's discretion if a pole is a few mm outside this variance: close counts, as it is not a critical measurement.

### 3.3 *Fittings and Lines*

Measurers: Note that “the diameter, length, and material of all running rigging is not restricted.”

- 3.3.1 *Builder supplied hardware may be replaced provided the mechanical advantage of the system is not increased and the locations of the system and its cleat do not materially change.*
- 3.3.1.1 *Mainsheet – 4:1 maximum with a single mainsheet cleat. Measurers: note that it is OK for the block on the boom to be suspended on a rope strop of any length*
- 3.3.8 *A single line, cleat and turning block, may be installed on each side for combination barber hauler/tweaker. Location and means of attachment are optional. Measurers: Note that barber hauler/tweakers may also be used on the jib sheets, as well as on spinnaker sheets.*
- 3.3.10 *Boats must be equipped with bow and stern pulpits. Measurers: Note that if a pulpit or pushpit has been removed due to damage and will soon be replaced, it is OK for the boat to race in this condition for a reasonable time period (except at an NA's or Canadian's unless it is impossible to source one in time for either event). Furthermore, it is OK if an owner wishes to temporarily tape a batten or coat-hanger on the bow of the boat to prevent the spinnaker sheet from going underneath the boat.*
- 3.3.11 *Central mainsheet cleating - the mainsheet system may be altered to allow the mainsheet cleat to be fixed to the traveler track using a swivel cam. Measurers: Note that it is OK for an owner to attach a rope or wire strop or metal rods or other support structures between the metal support plate (a barney post) and the cockpit floor or sides to prevent the plate from flexing under load.*
- 3.3.14 *The bow or stern mooring cleats may be replaced with alternative suitable mooring points. Measurers: Note that “alternative suitable mooring points” means u-bolts or similar, and not just the nearby pushpit or pulpit base.*

### 3.4 *Hull and Interior*

*Additions to personalize the interior, which do not improve performance, are allowed as long as the structural integrity of the boat is not impaired. Measurers: Note that if an owner has personal physical issues and wishes to loosely bolt a crossbeam onto the two wood bulkheads so that the outboard motor can be suspended on it, this exception can be Dispensated. (and has been done with one Vancouver boat, namely “Christian Bligh”, owned by Colin Potter) The crossbeam cannot be tightly bolted in place or it will add structural stiffening, therefore the bolt holes must be drilled over-*

sized, preferably double or triple the thickness of the bolt. (which will require oversized washers at each end of the bolt)

- 3.4.1 *All bunkboards and cushions may be removed. Measurers: Note that bunkboards may be permanently hinged in place which then count towards the minimum boat weight and are not considered “Corrector Weights”. Note also that the forward bunkboards can be configured and screwed or bolted in place to create a “ski jump” for the mainsail to slide easily into the forepeak.*
- 3.4.3 *The bunkboard immediately aft of the mast may be permanently secured in place. The bunkboard shall be made from 12.7mm (.04 feet) medium density overlay, plywood or equivalent. Measurers: Note that it is OK if the bunkboard aft of the mast has a cutout in it to enable an outboard motor to be mounted on a bracket on the aft face of the fiberglass bulkhead. Secondly, it is common practice to insert cutouts forward of the wooden bulkheads on either side for ventilation or storage purposes.*
- 3.4.5 *The cockpit drains may be altered or replaced provided the watertight integrity of the boat and the effectiveness of the drains is not diminished. Measurers: Note that it is OK for owners to remove the original drainage equipment, and insert straight tubes from the aft end of the cockpit and connect to the original or alternative drain holes on the aft of the boat.*

### **3.6 Sails**

- 3.6.6 *Dispensations - Any yacht may apply to the class Technical Committee for a dispensation from the requirements of Rule 3.6 if that yacht believes that due to some special situation, these rules are not equitable for the yacht. The decision of the technical committee shall be binding and shall form part of the yacht's Sail Register.*

### **3.7. Weight and Measurement Requirements**

- 3.7.4.1 *Dispensations - Any boat may apply to the Fleet Measurer for a dispensation from the requirement of Rule 3.7.4 if that boat believes that due to some special situation, the rule is not equitable for the boat. The decision of the Fleet Measurer shall be binding and be listed on the Measurement Certificate.*

Measurers: Note that you need to check for water in the hull interior prior to weighing. Collection points for water include the forepeak, around the mast step, under the cabin floor, and in the aft area (aka “the basement”). If a boat is weighed when it is soaking wet from rain or post-competition, an allowance should be made for water on the deck, hull, and absorption in ropes, possibly as much as 2 to 3 pounds.

Weigh scale instructions (for RVYC scale):

- Power on, and press “Mode” to set to pounds if in Kg.
- Press “Tare” with lifting straps and shackles on the hook

- 3.7.7 *The rudder and shaft shall weigh a minimum of 18.1kg (40lbs). If it weighs less, corrector weight shall be securely fastened to the rudder tube. Measurers: Note that this weighing process is almost never done and not considered essential. Rudders made of materials other than those supplied by the Builder are not considered Class legal.*



- 3.7.8 *All yachts must carry an outboard engine with a suitable bracket. If the engine and bracket together weigh less than 13.6kg (30lbs), corrector weight shall be added to either the motor or the bracket. Fuel may not be counted as part of the engine weight calculation. Measurers: Note that this is a safety issue. All boats must have an outboard engine that works. Period.*
- 3.7.8.1 ***Fleet 3 Local Variance:** If an outboard weighing more than 30 lbs. is carried, the excess weight may be taken as a credit towards bringing the boat up to minimum weight.*
- 3.7.9 *Keel and rudder work, other than minor painting and sanding invalidates the **Measurement Certificate**, however, only the modified foil(s) need to be measured to revalidate the **Measurement Certificate**. Revalidation does not extend the life of a **Measurement Certificate**.*
- 3.7.11 *The maximum weight of the keel shall be 413kg (910 pounds). Measurers: Note that this is impractical to do on any boat unless the keel is being replaced.*

## ***Appendix A – Sail Measurement***

Measurers: Sailmakers are responsible for measuring their own sails that they build and also affixing the Class Certification Mark to the sail, dating it, and signing it. It is usually placed at the tack of the sail.

If a sail has been delivered to an owner with no Certification Mark attached, it is the responsibility of the sailmaker to provide one to the owner so it can be affixed to the sail, either by the owner or the Measurer. It is not the responsibility of a Measurer to re-measure sails once they have been delivered to an owner.



Certification Marks are supplied by the Secretary of Fleet One to all the North American sailmakers upon request (free for Canadian sailmakers and a nominal fee for US ones), and most Measurers have additional blanks on hand.

## ***Appendix B – Foil Sections***

These tables are included to give repair crews something to work from in the event of need. The primary intent of the Class is to preserve the sections produced by the Builder.

### Keel Section

The table below provides for the minimum and maximum keel measurements:

Name	Description	Length	Tolerance
KF	Front leading edge	1226mm (4.02 feet)	+/- 10mm (.03 feet)
KB	Bottom edge	450mm (1.48 feet)	+/- 10mm (.03 feet)
KA	Aft edge	1186mm (3.89 feet)	+/- 10mm (.03 feet)
KT	Top edge	751mm (2.46 feet)	+/- 10mm (.03 feet)

The keel's maximum thickness shall be as defined in the table below. There shall be no fillets (Measurers: this means that where the keel attaches to the hull there should be a roughly 90 degree angle and not a rounded curve induced via filler material). Between these measurement points, the keel shall change thickness roughly in proportion to the change in chord. This means no significant bulges or hollows.

Station	Location from top of keel	Thickness	Tolerance
A	127mm down Aft edge	86mm (.28 feet)	+/- 6mm (.02 feet)
B	610mm down Aft edge	77mm (.25 feet)	+/- 6mm (.02 feet)
C	1143mm down Aft edge	57mm (.19 feet)	+/- 6mm (.02 feet)

The keel's leading-edge radius shall uniformly measure between a minimum of 5mm and a maximum of 9mm.

All measurements shall be to the projected corners of the keel. (Measurers: note that this is more difficult to do when a boat is sitting on a trailer as opposed to hanging on a crane)

All Station measurements shall be done perpendicular to the Aft edge of the keel.

**Keel Position:** The keel shall be located so that the leading edge is 4470mm (14.67 feet) +/- 25mm (.08 feet) from the intersection of the transom and the hull surfaces measured along the hull surface at the centerline. Boats that were supplied by the Builder with keel positions outside of this range may apply to their local Fleet Measurers for dispensation.

Measurers: With regard to thickness measurements of the keel:

- Use the parallel rule and take the average of the fore and aft measurements because it can be a bit challenging to make the parallel exactly parallel (i.e. take the measurements at the leading and trailing edge of the keel).

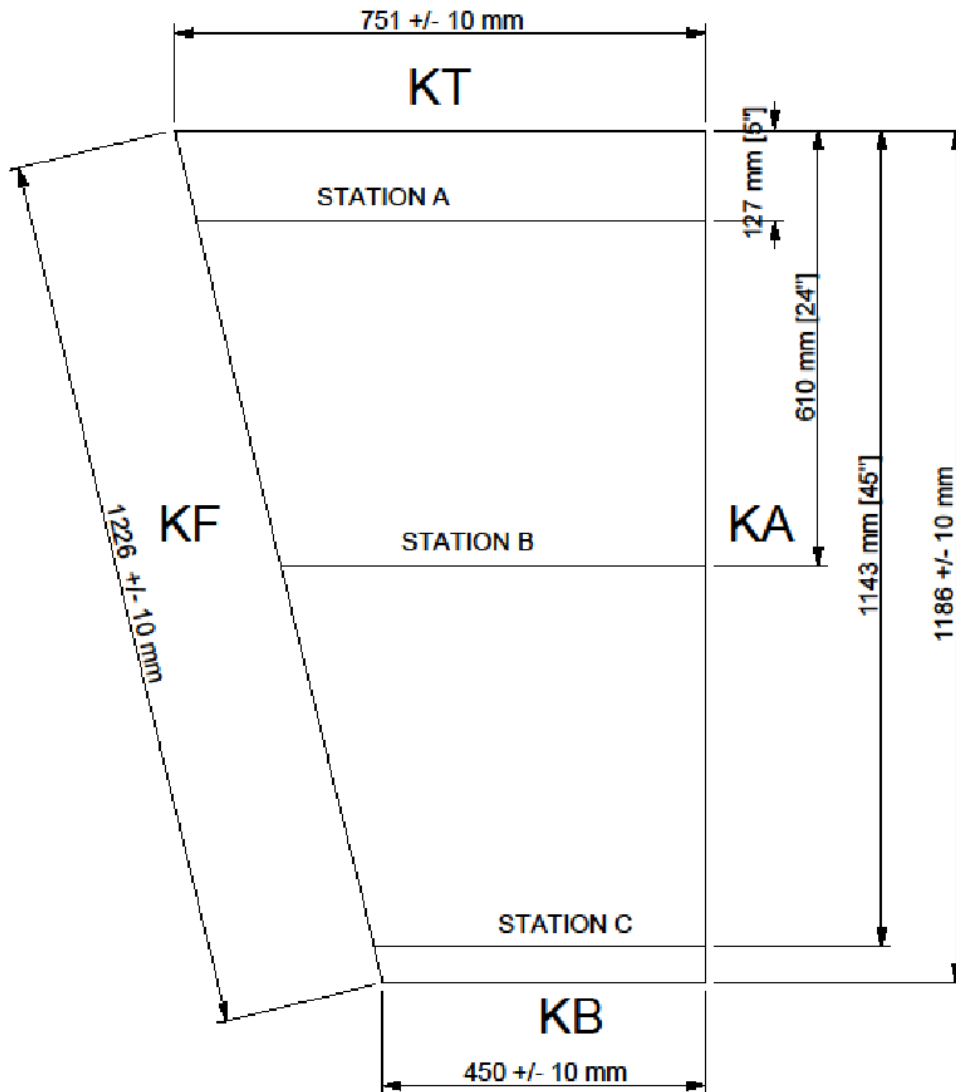

KEEL DIMENSIONS AND STATIONS

### ***Rudder Section***

*The table below provides for the minimum and maximum rudder measurements:*

<b><i>Name</i></b>	<b><i>Description</i></b>	<b><i>Length</i></b>	<b><i>Tolerance</i></b>
<i>RF</i>	<i>Front leading edge</i>	<i>935mm (3.07 feet)</i>	<i>+/- 10mm (.03 feet)</i>
<i>RB</i>	<i>Bottom edge</i>	<i>399mm (1.29 feet)</i>	<i>+/- 10mm (.03 feet)</i>
<i>RA</i>	<i>Aft edge</i>	<i>974mm (3.2 feet)</i>	<i>+/- 10mm (.03 feet)</i>
<i>RT</i>	<i>Top edge</i>	<i>470mm (1.56 feet)</i>	<i>+/- 10mm (.03 feet)</i>

*The rudder's maximum thickness shall be as defined in the table below. There shall be no fillets. Between these measurement points, the rudder shall change thickness roughly in proportion to the change in chord. This means no significant bulges or hollows.*

*All measurements shall be to the projected corners of the rudder.*

*All Station measurements shall be done perpendicular to the Aft edge of the rudder.*

<b><i>Station</i></b>	<b><i>Location from top of rudder</i></b>	<b><i>Thickness</i></b>	<b><i>Tolerance</i></b>
<i>A</i>	<i>152mm down Aft edge</i>	<i>69mm (.23 feet)</i>	<i>+/- 5mm (.02 feet)</i>
<i>B</i>	<i>796mm down Aft edge</i>	<i>63mm (.21 feet)</i>	<i>+/- 5mm (.02 feet)</i>

**Measurers:** With regard to thickness measurements of the rudder:

- Use the parallel rule and take the average of the fore and aft measurements because it can be a bit challenging to make the parallel exactly parallel (i.e. take the measurements at the leading and trailing edge of the rudder).



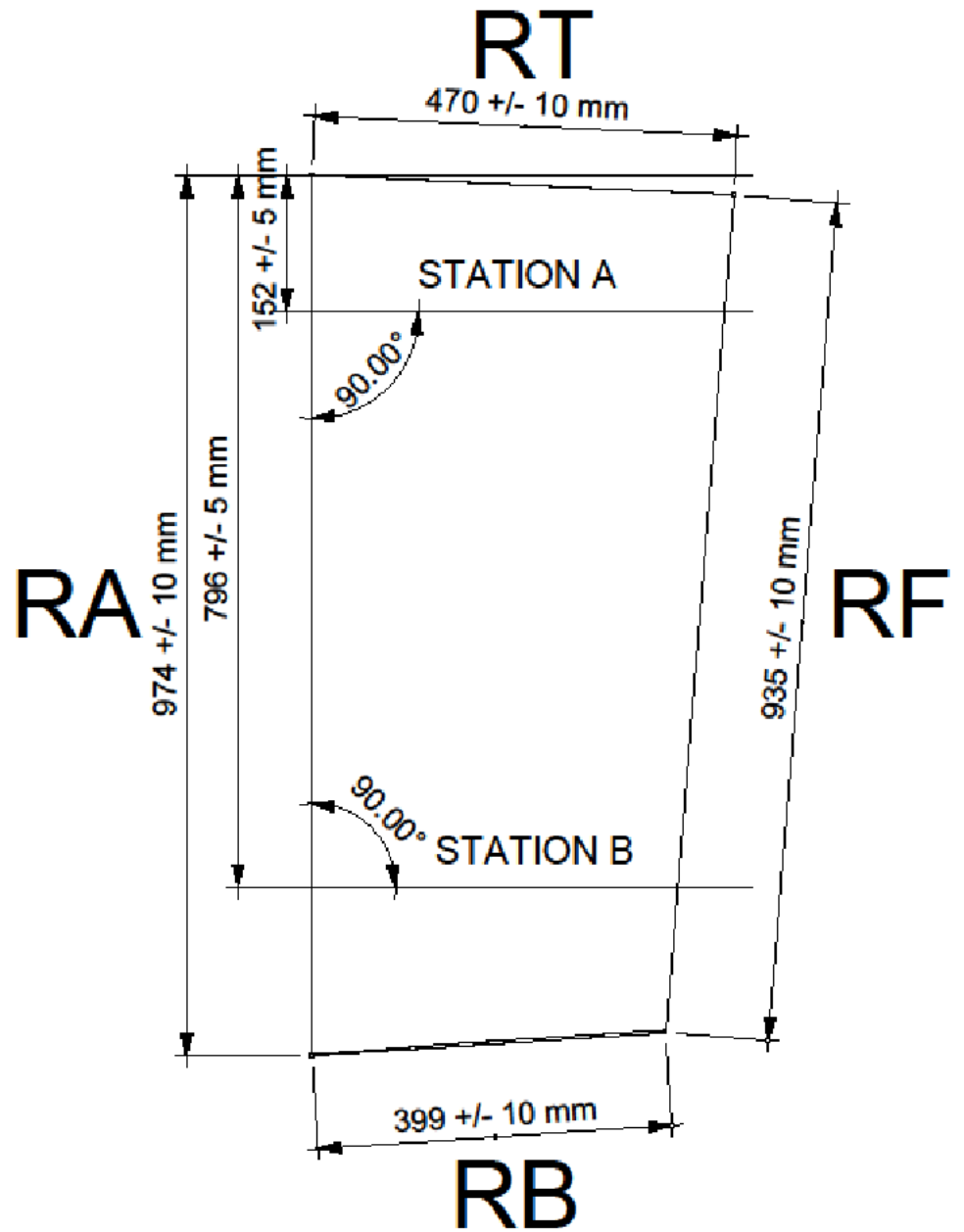

RUDDER DIMENSIONS AND STATIONS

OCT. 27, 2009 cls